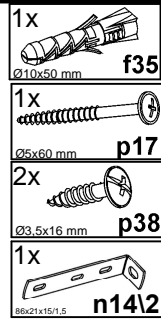
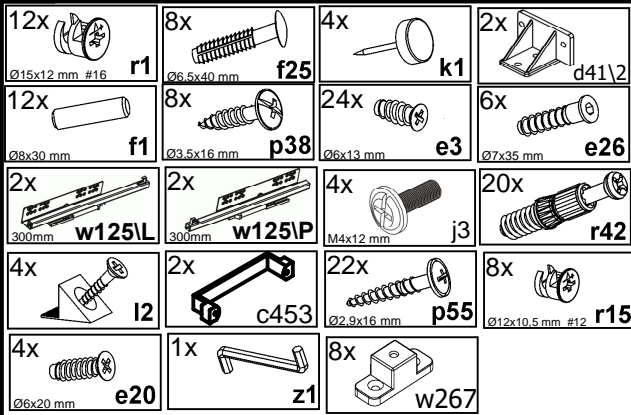
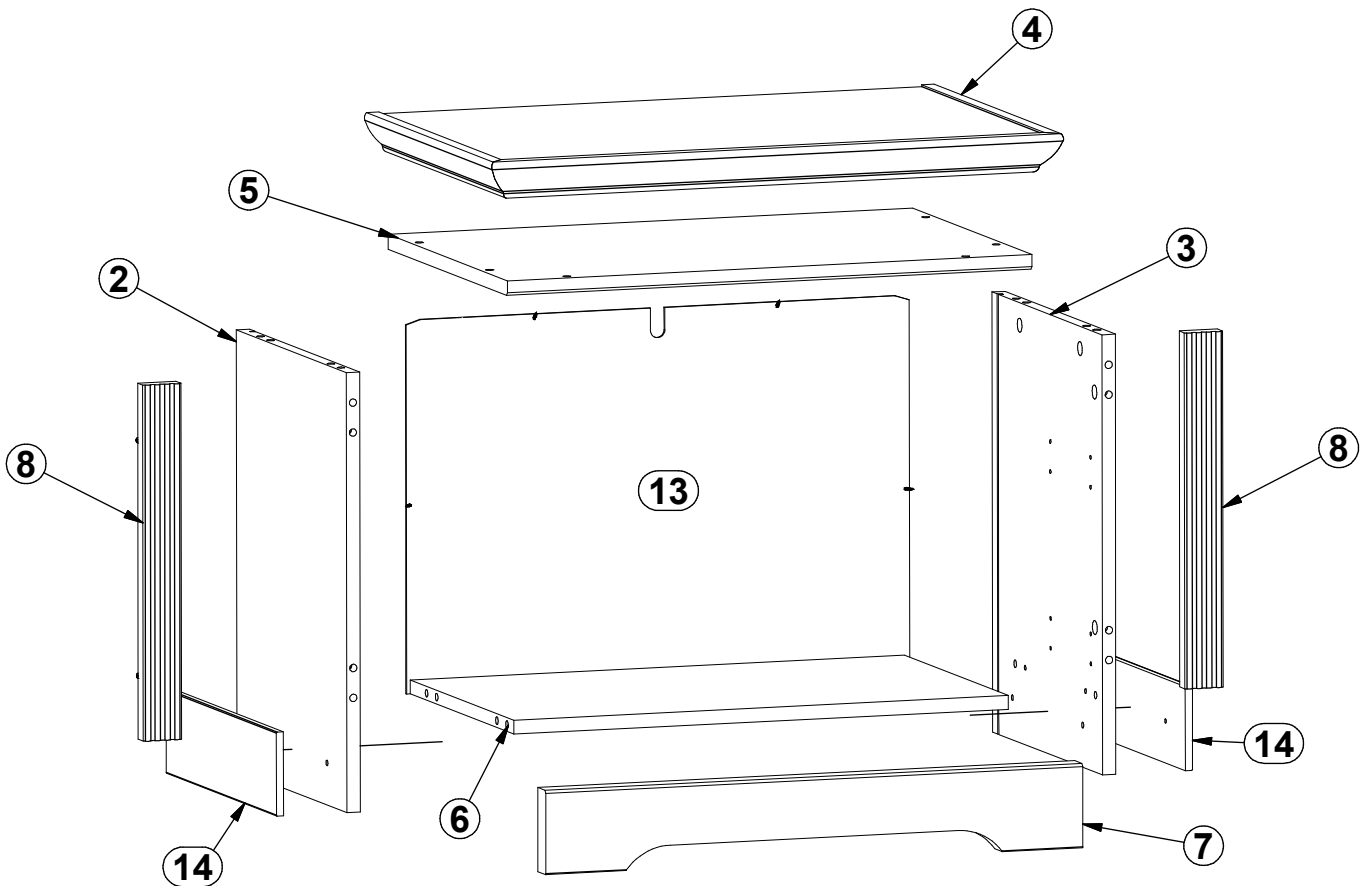
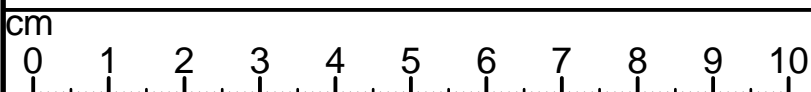
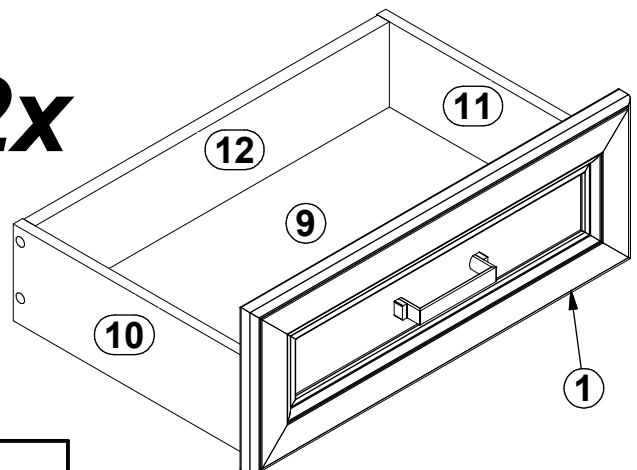

A**L126-SFK2S****38-961- --, 38-881- --****2 / 13**

A	B	C1	C2	C3	D
1	L126-0004	496	185	22	1\1
2	L126-1009	471	350	15	1\1
3	L126-1010	471	350	15	1\1
4	L126-2006	642	406	43	1\1
5	L126-2005	589	380	16	1\1
6	L126-3005	555	330	15	1\1
7	L126-4009	603	90	25	1\1
8	L126-5011	381	43	19	1\1
9	WSP-9420	474	308	2.5	1\1
10	ZQ6-517	300	110	12	1\1
11	ZQ6-518	300	110	12	1\1
12	ZQ6-5263	464	97	15	1\1
13	L126-9003	400	565	2.5	1\1
14	L126-5012	350	90	8	1\1

**2x**

1 

I

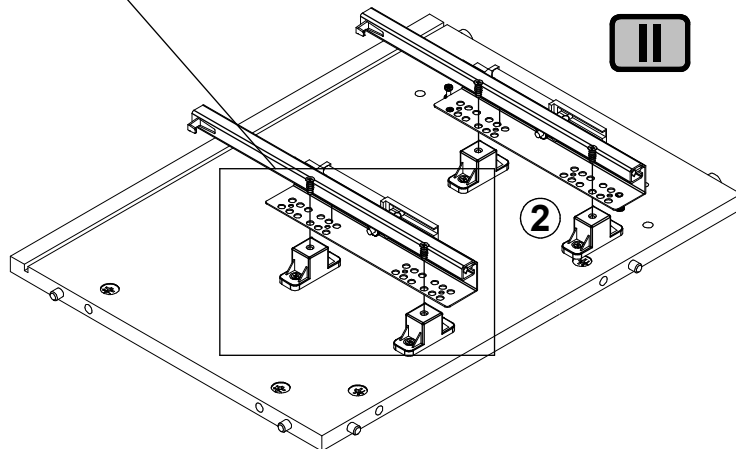
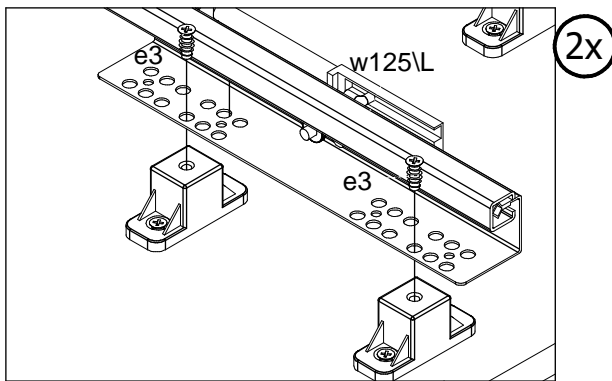
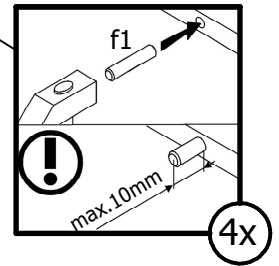
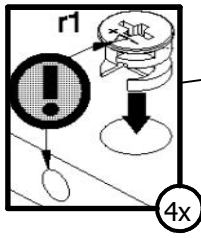
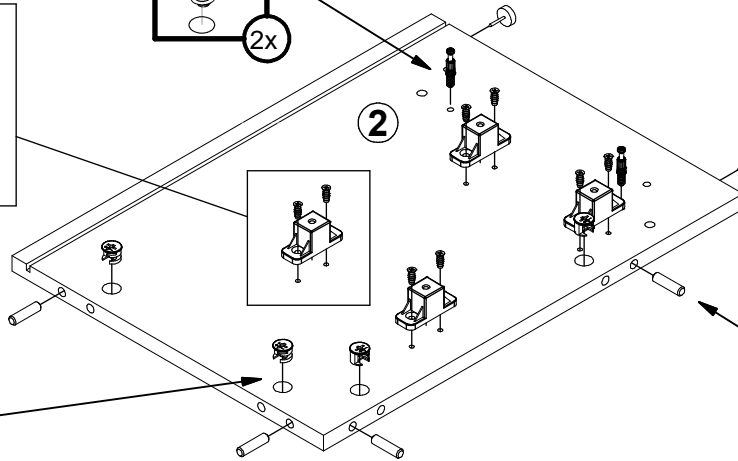
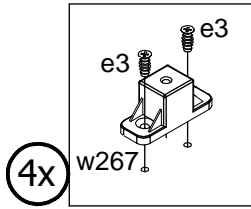
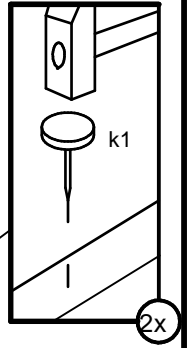
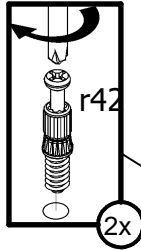

2

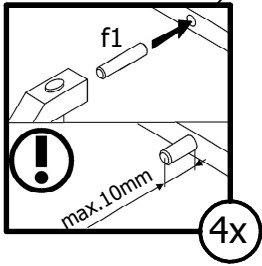
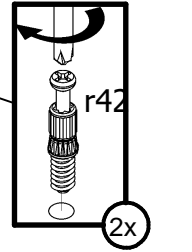
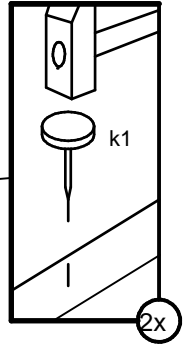
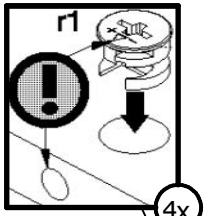

3

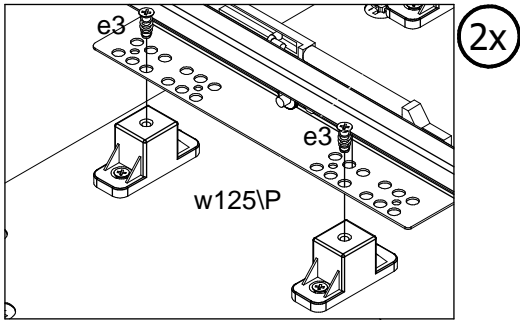
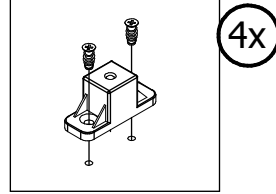

3

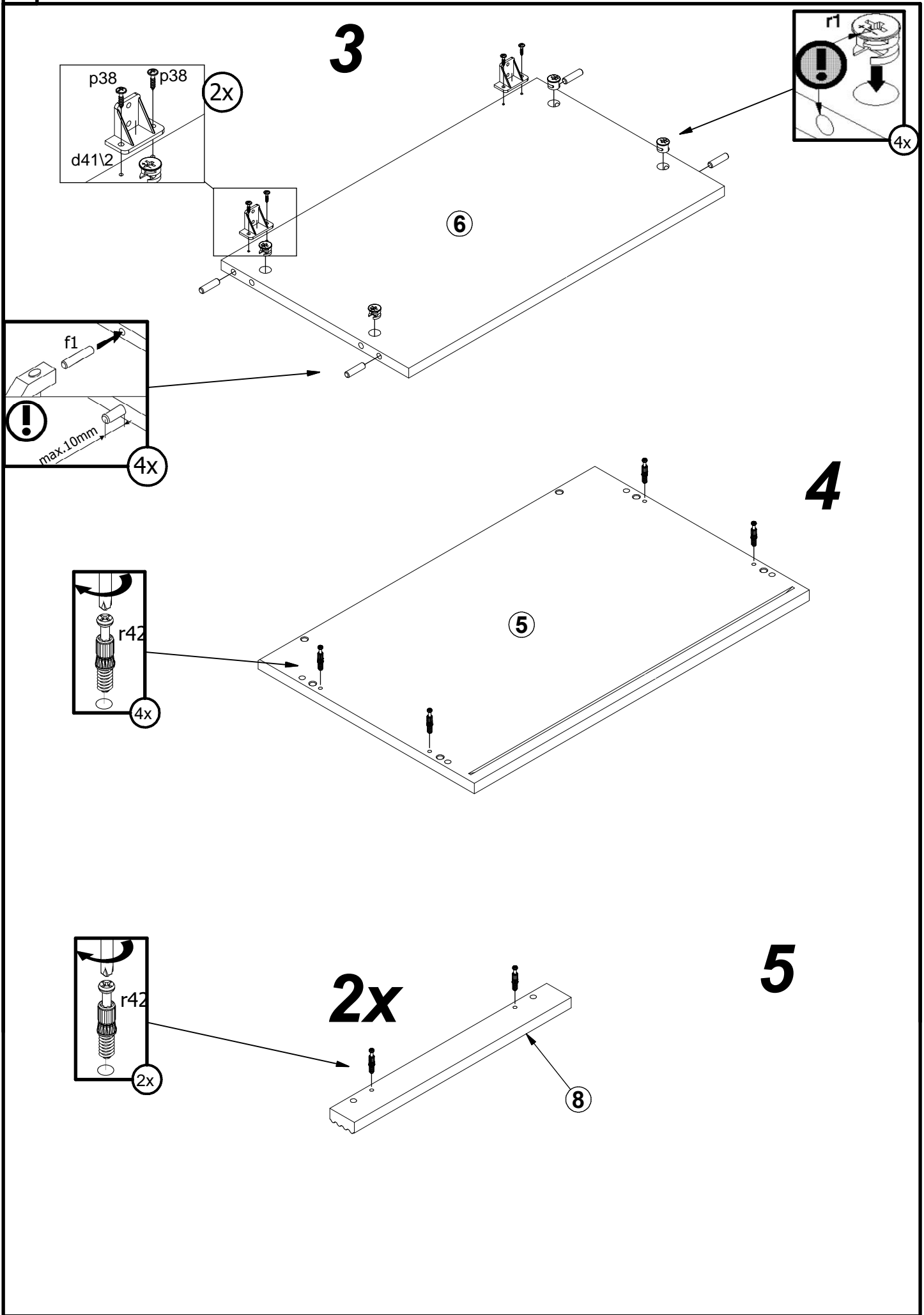

6

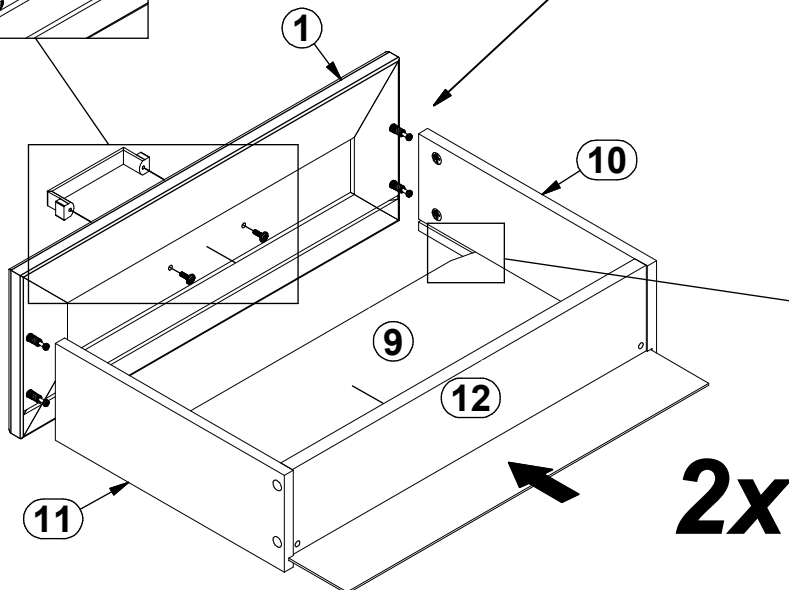
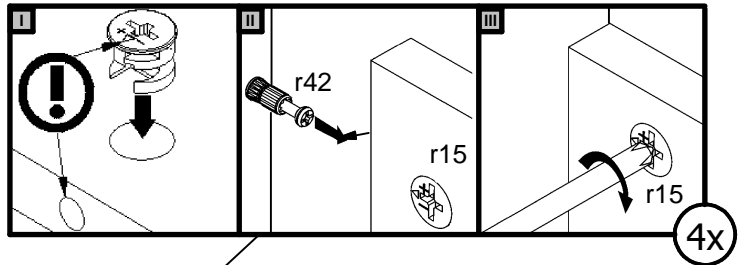
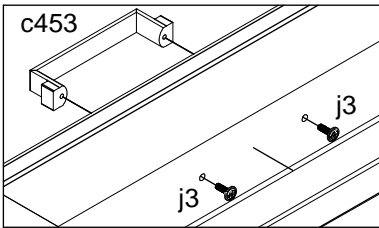
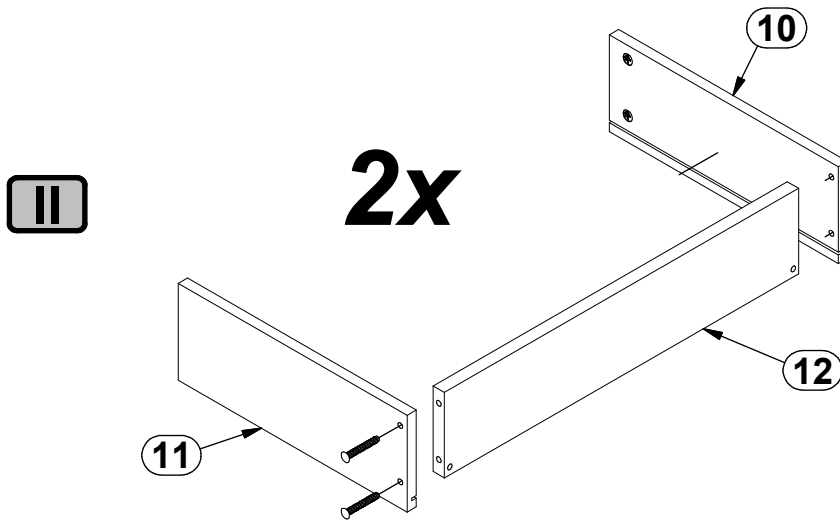
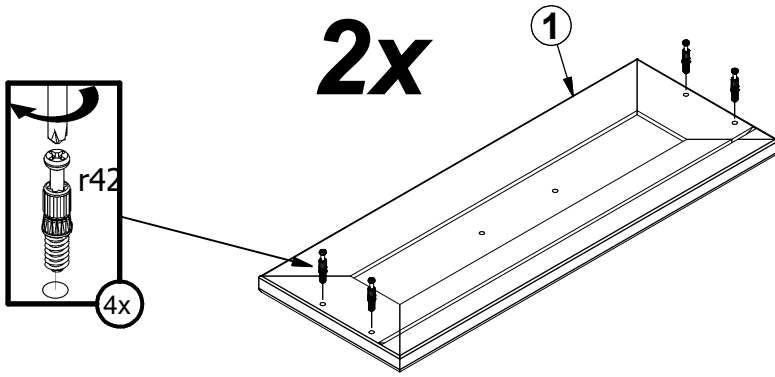

IV

2x

6x

p55

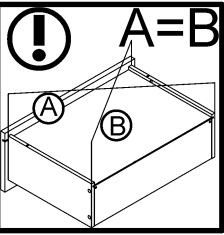
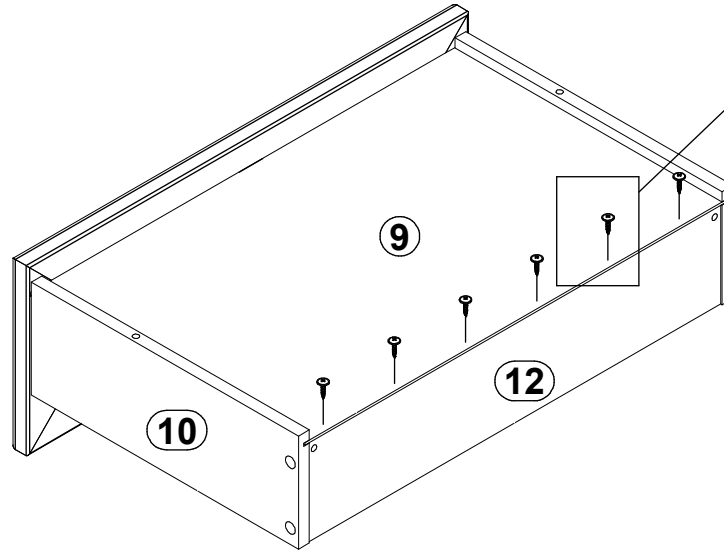

7

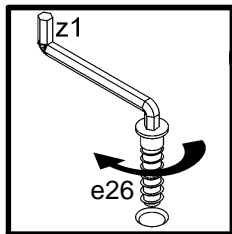

6x

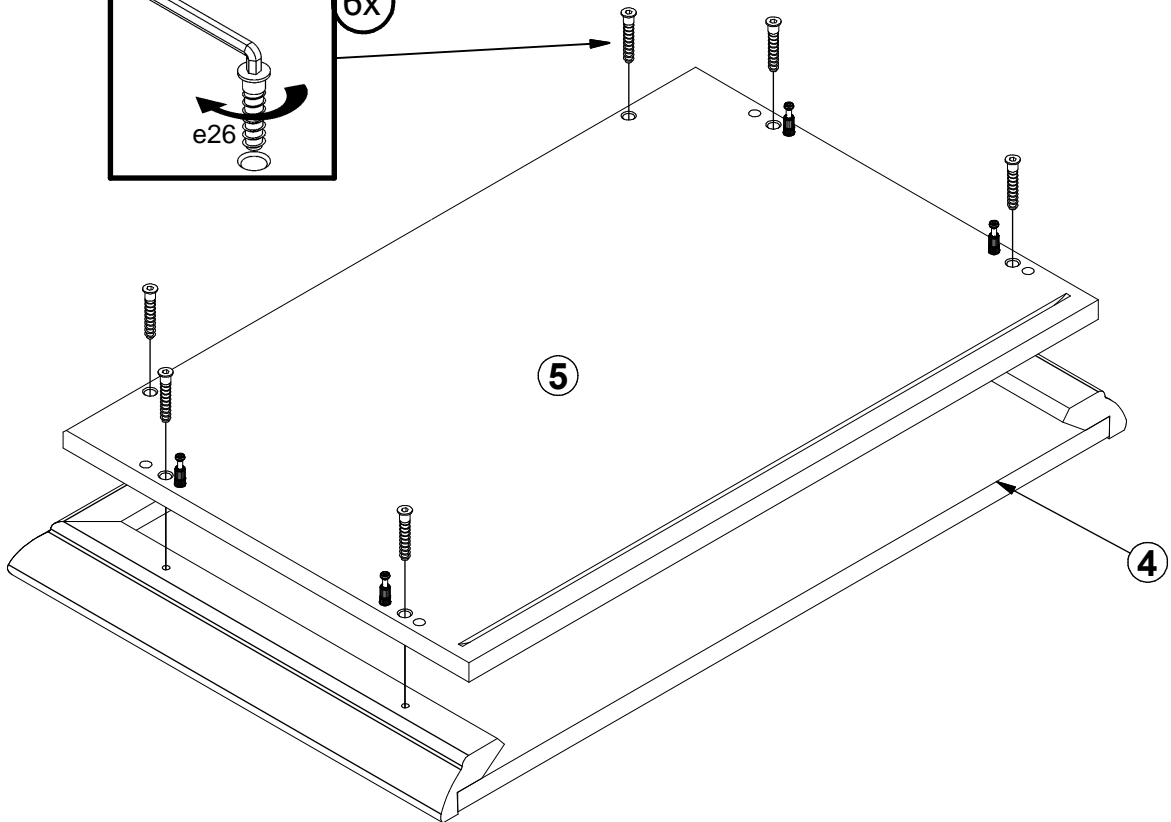

8

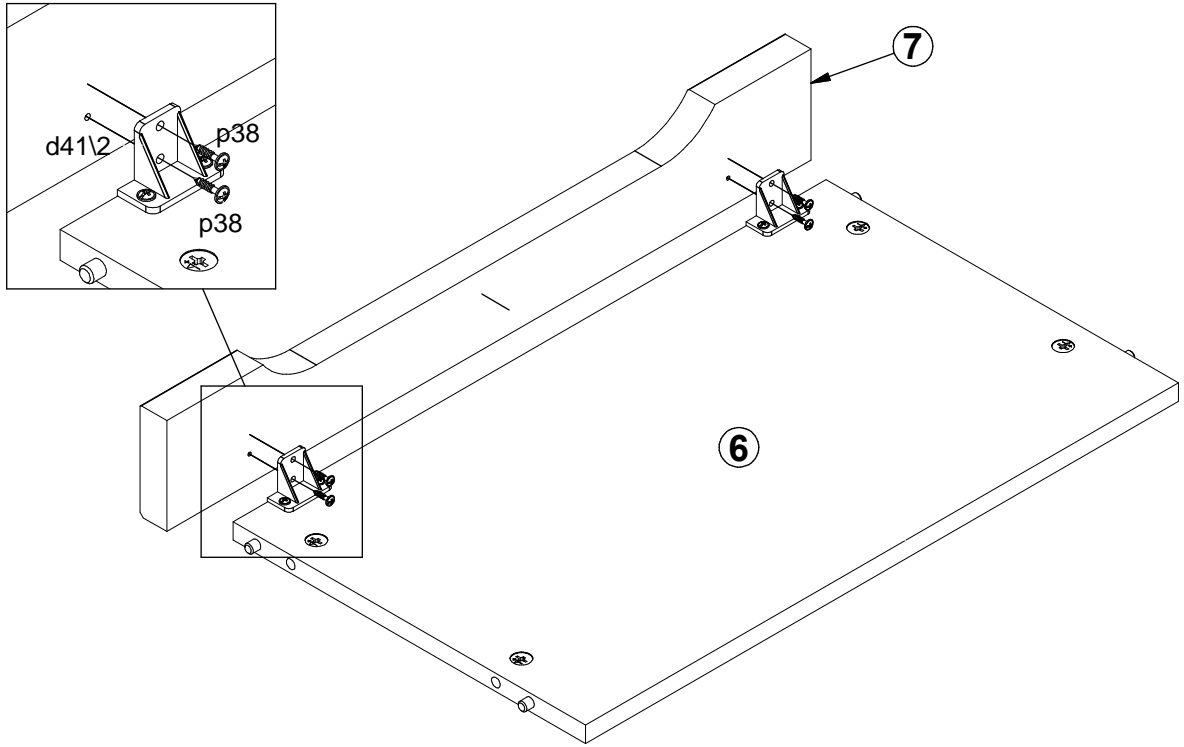

9

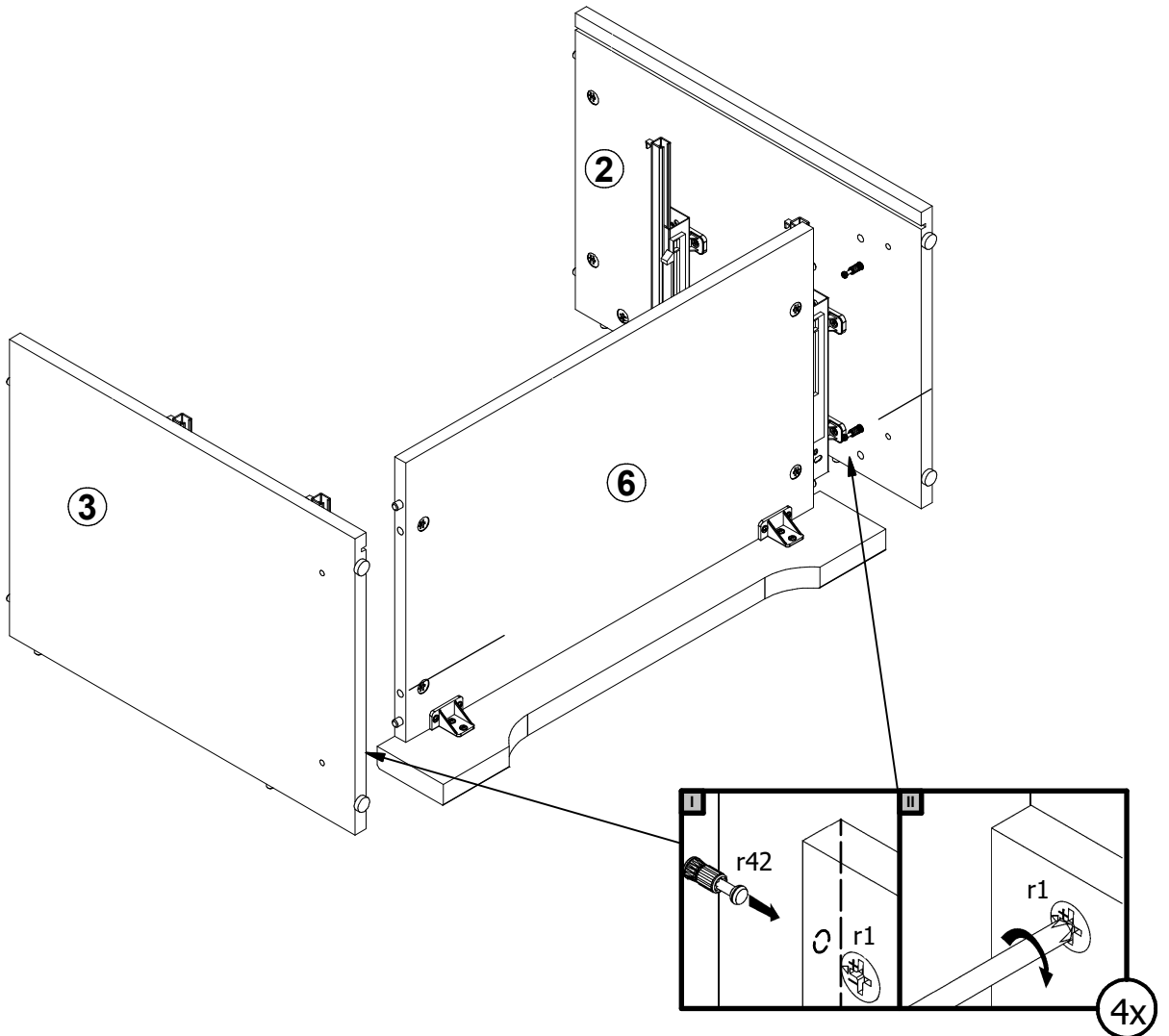

10

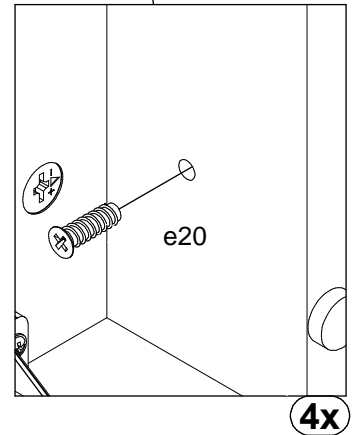
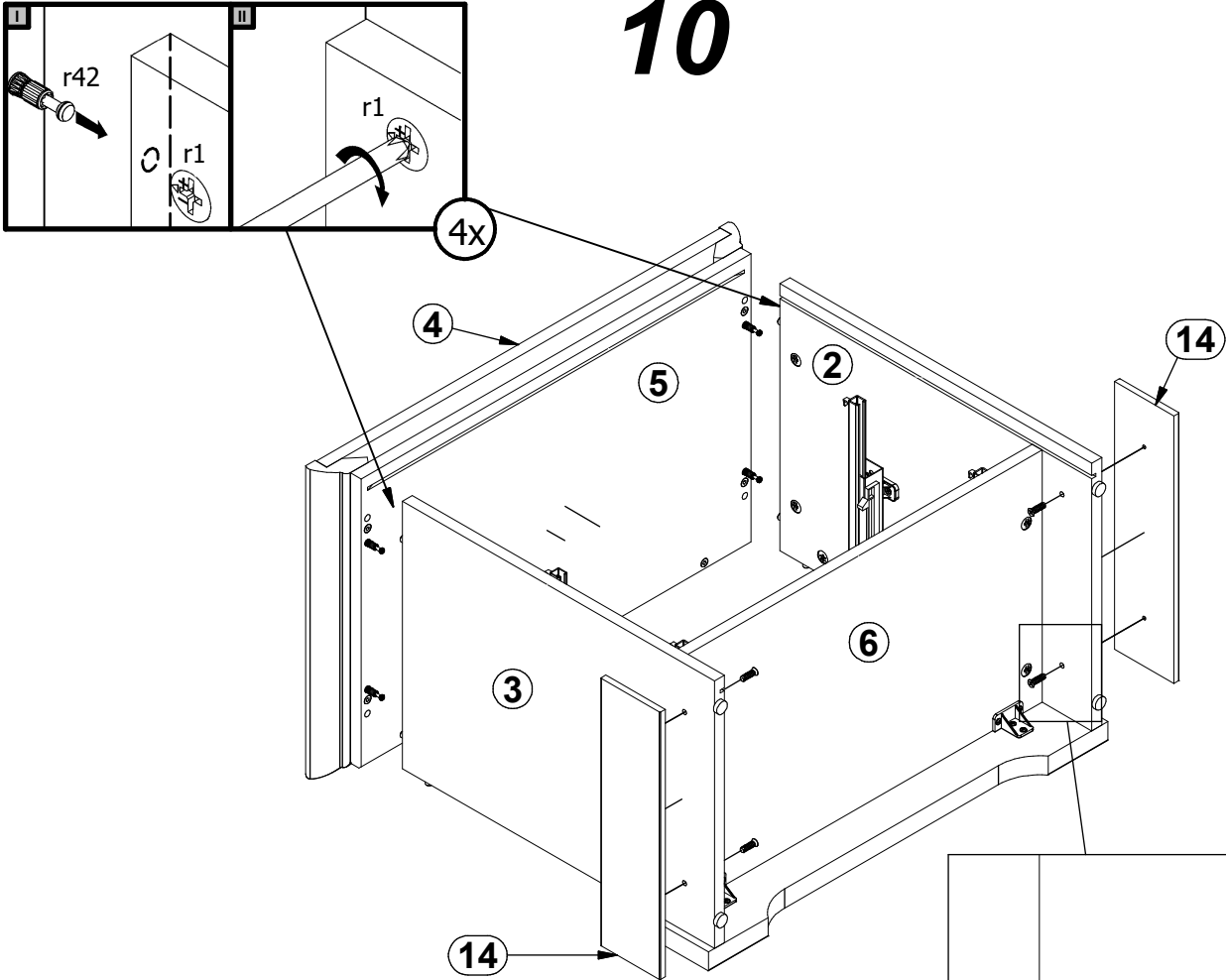

11

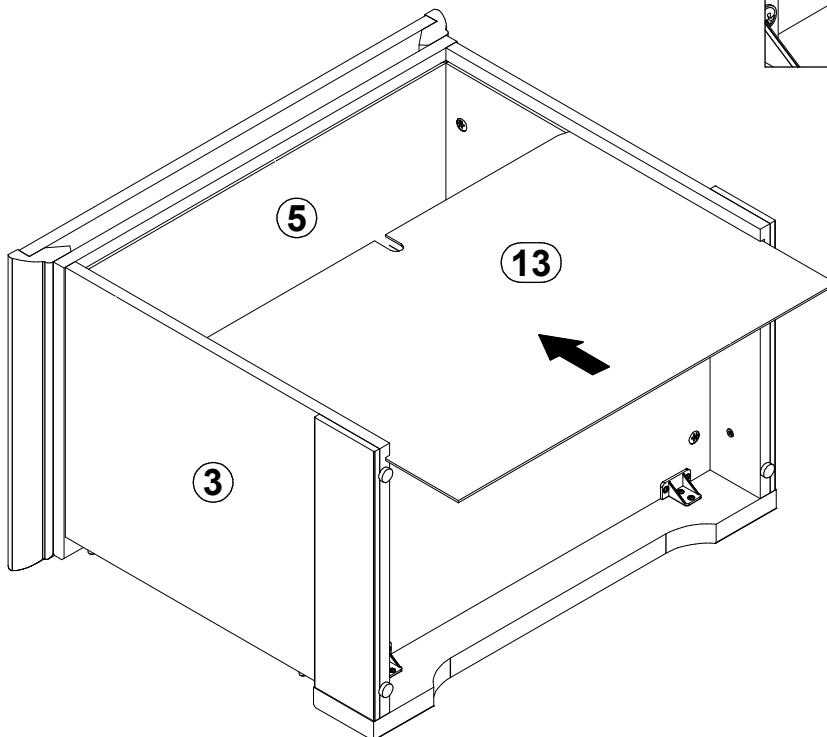

12

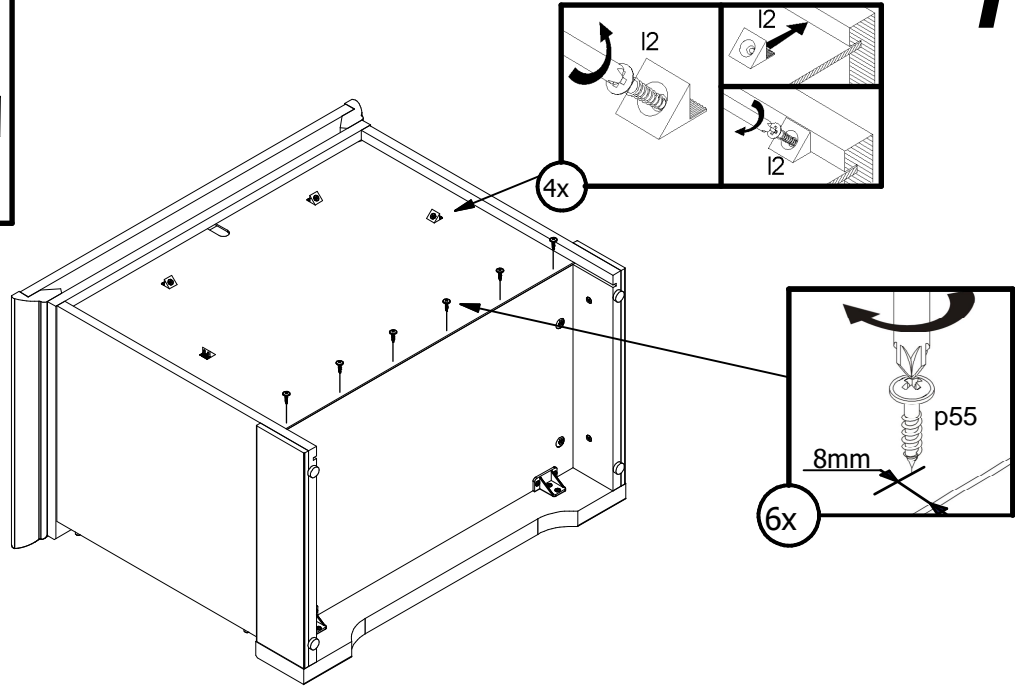
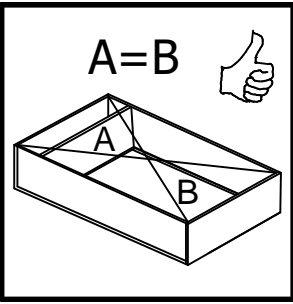

13

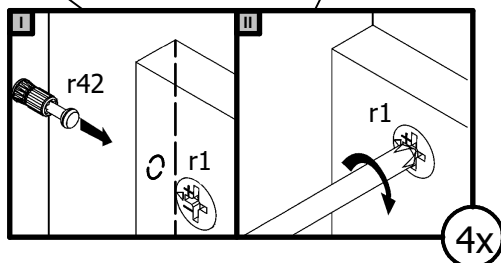
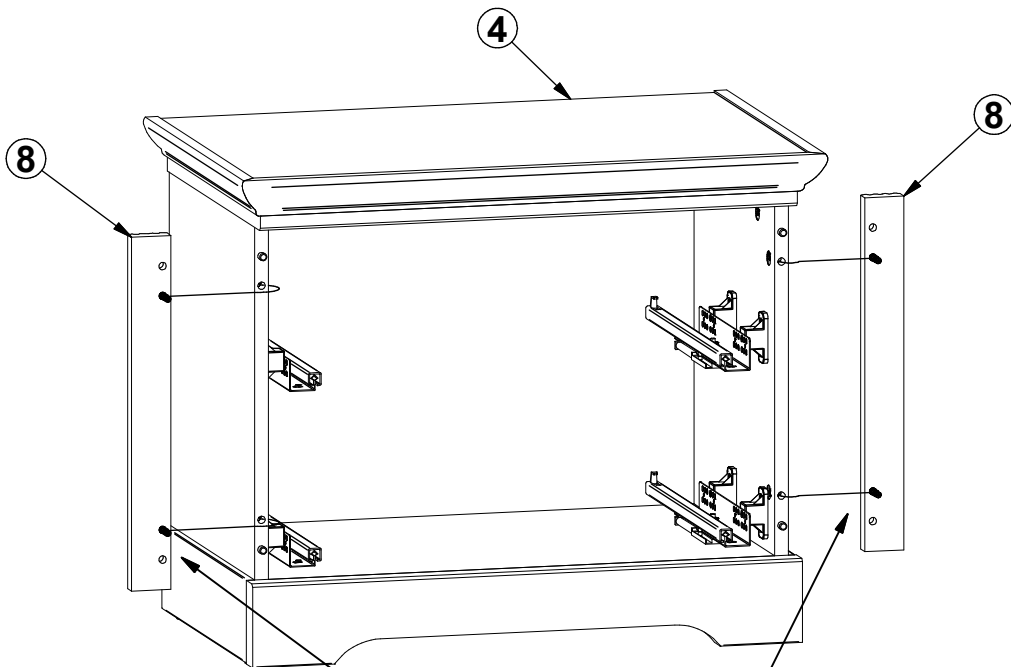

14

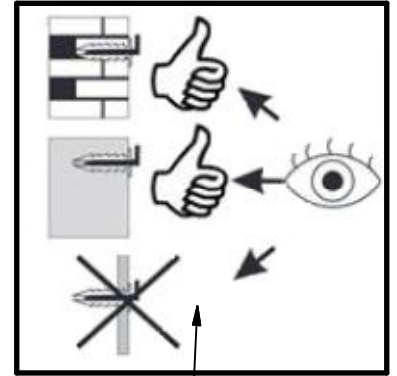
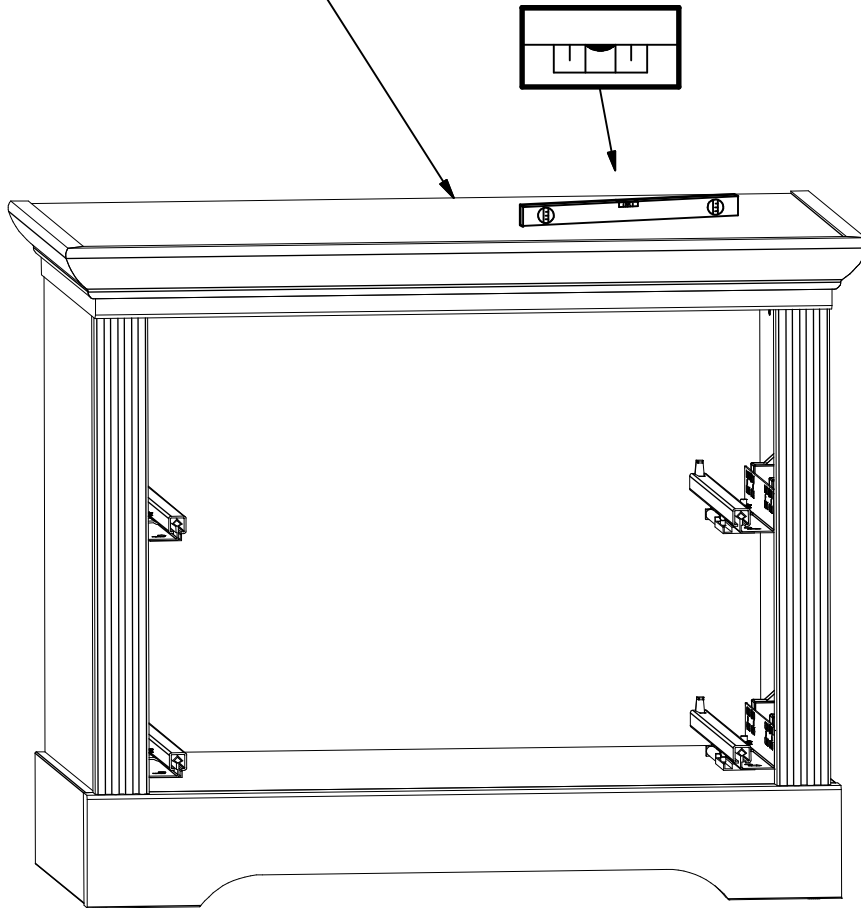
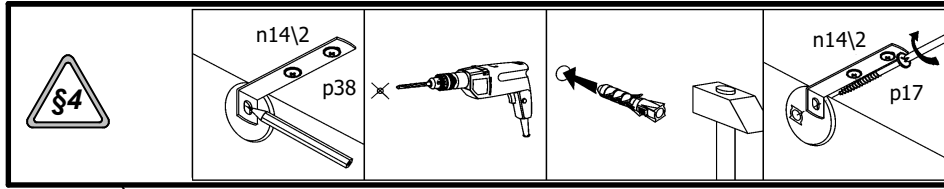

15

