

A	B	C1	C2	C3	D
1	M249-5015	107	65	22	1/3
2	M249-5025	107	65	22	1/3
3	S510-0016	946	146	16	1/3
4	S510-0017	462	396	16	2/3
5	S510-0053	462	396	16	2/3
6	S510-1028	462	473	16	2/2
7	S510-1029	462,	473	16	2/3
8	S510-1030	298	393	16	1/3
9	S510-1031	462	393	16	1/3
10	S510-2011	1890	500	32	3/3
11	S510-2012	1836,	473	18	2/3
12	S510-3020	969	393	22	1/3
13	S510-3021	818	393	16	1/3
14	S510-4005	942,5	80	22	1/3
15	S510-5057	587,	65	22	1/3
16	S510-5058	587,	43	22	1/3
17	S510-5059	587,	43	22	1/3
18	S510-5073	587,	65	22	1/3
19	S510-5074	587,	65	22	1/3
20	S510-9012	982	472	2,5	2/3
21	S510-9013	472	832	2,5	2/3
22	WSP-9352	912	358	2,5	1/3
23	ZQ6-5143	902	97	15	1/3
24	ZQ6-519	350	110	12	1/3
25	ZQ6-520	350	110	12	1/3

2x a205	2x b91	4x c453	4x d1 Ø5x17 mm	7x e1 Ø7x50 mm	3x n108 20x13x3,51	7x p55 Ø2,9x16 mm	8x j30 M4x22 mm	5x k1	10x l2	16x e3 Ø6x13 mm	12x e22 Ø7x28 mm	28x f1 Ø8x30 mm		
2x a202	2x b89	8x f13 Ø8x20 mm	8x f25 Ø6,5x40 mm	4x p25 Ø3,5x16 mm	4x p35 Ø3,5x10 mm	4x t35 350 mm	12x p38 Ø3,5x16 mm	8x p51 Ø3,5x15 mm	13x r1 Ø15x12 mm #16	8x r15 Ø12x10,5 mm #12	25x r42 20/11	2x W117/L 350 mm	2x W117/P 350 mm	1x z1
4x r3 Ø15x15 mm #22	5x s2 Ø16	1x s74 Ø60	2x f35 Ø10x50 mm	2x p17 Ø5x60 mm	4x p38 Ø3,5x16 mm	2x n14/2 86x21x15/1,5								

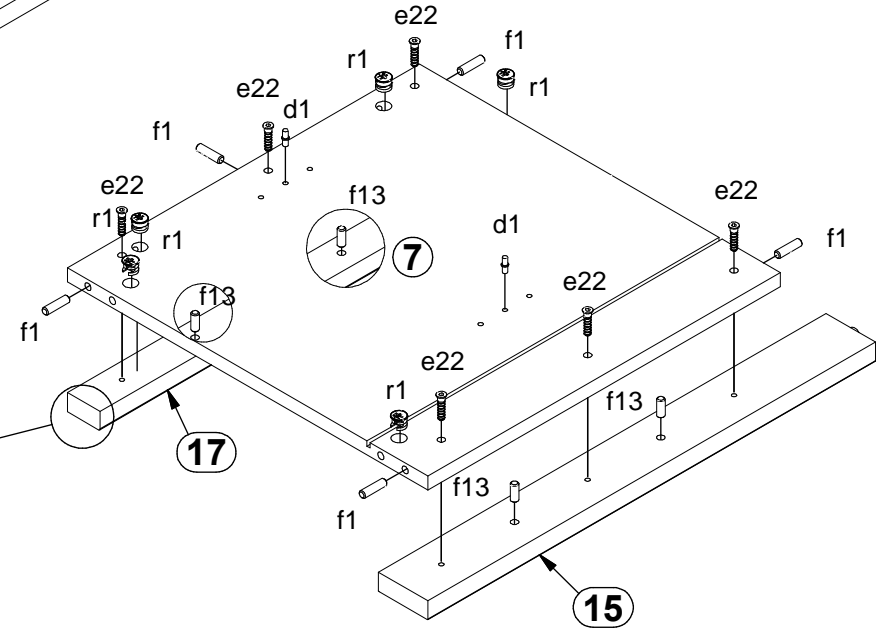

1

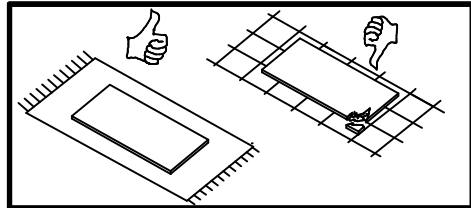
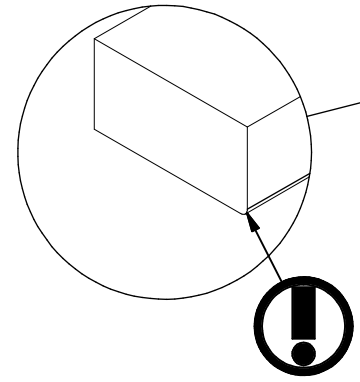
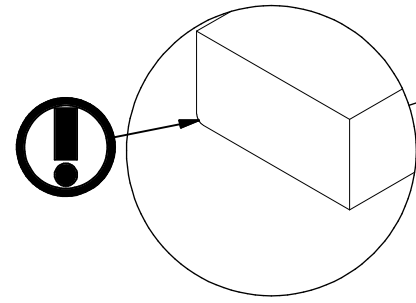
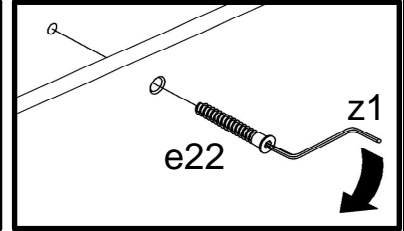
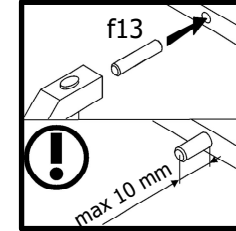
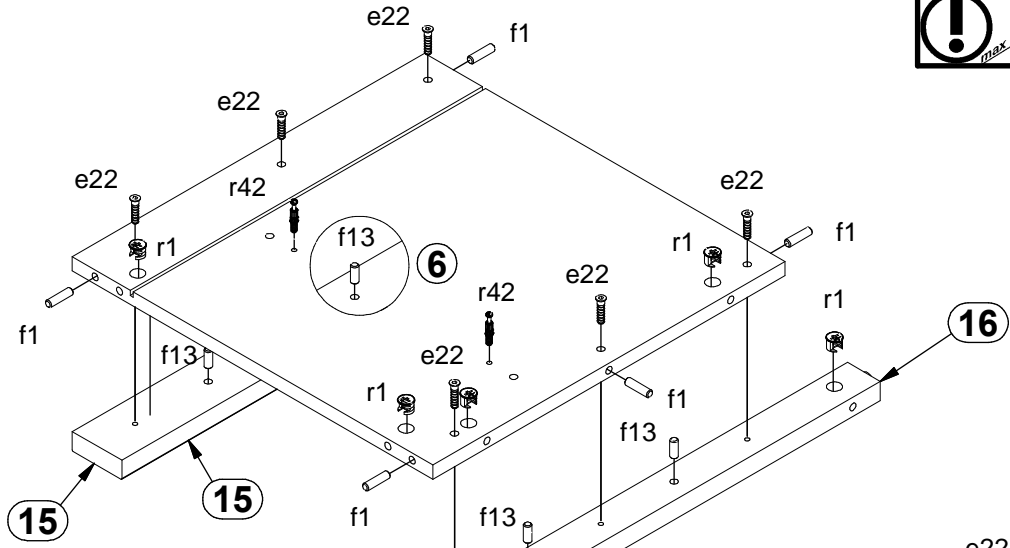
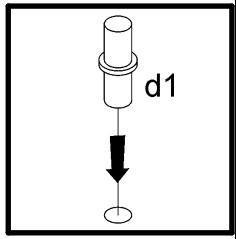
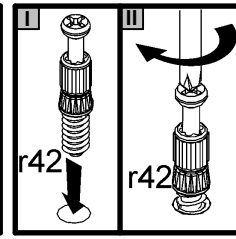
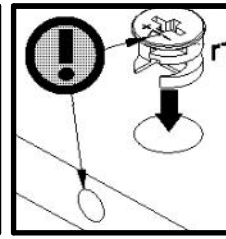
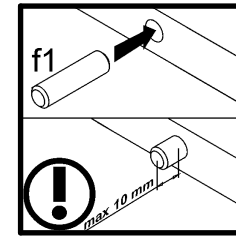
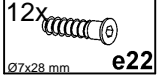
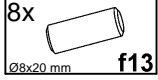
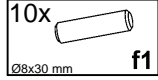
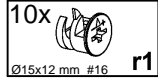
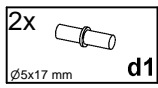
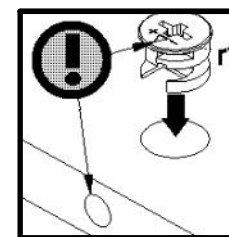
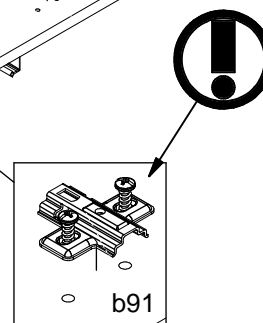
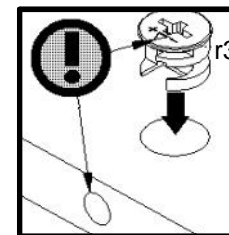
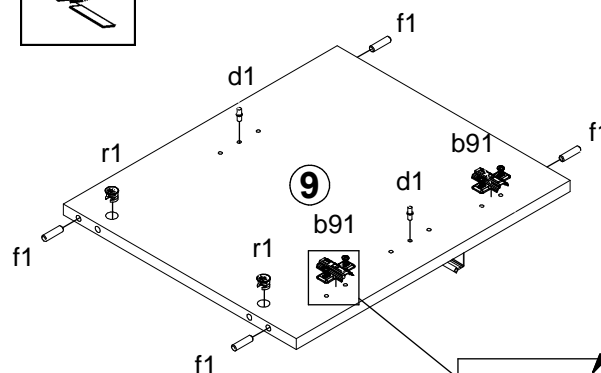
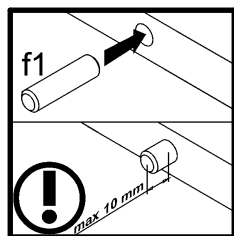
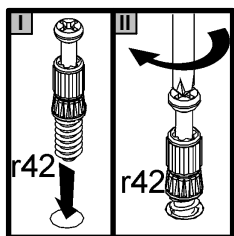
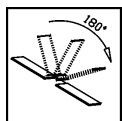
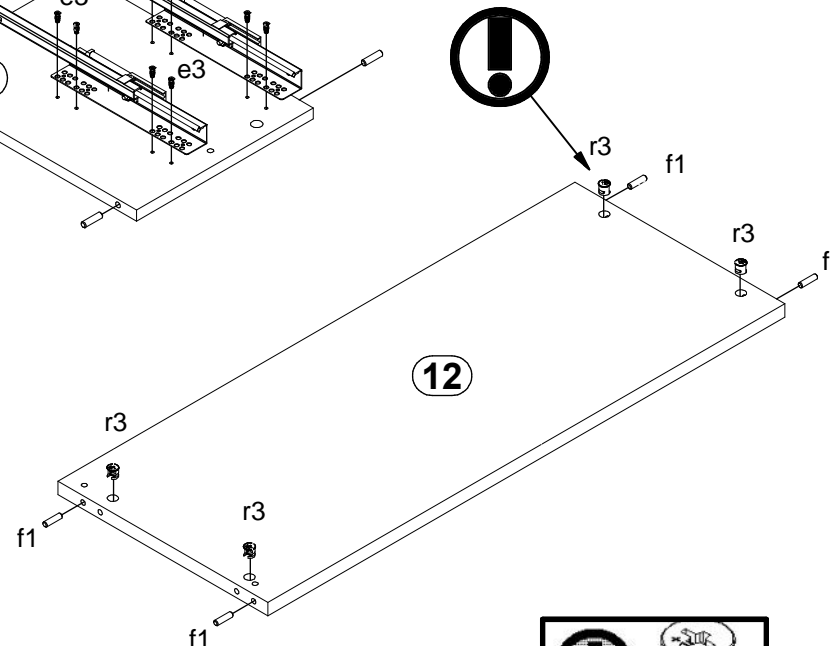
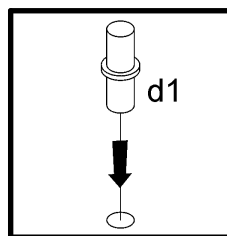
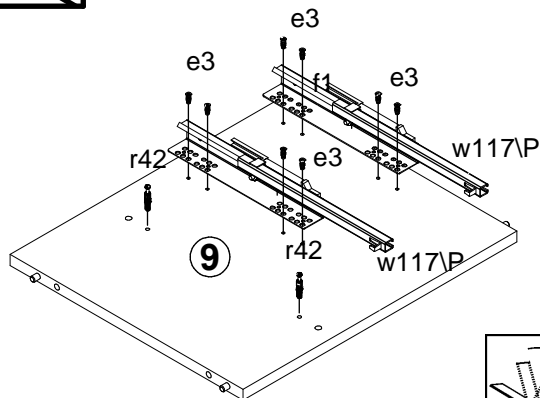
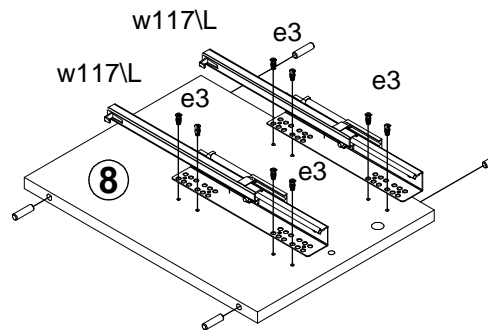
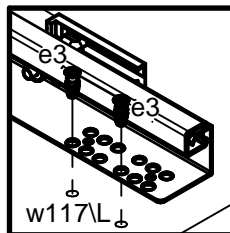
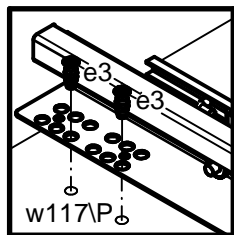

2x Ø15x12 mm #16 r1	12x Ø8x30 mm f1	2x Ø5x17 mm d1	4x Ø15x15 mm #22 r3
2x r42	2x 350 mm W117L	2x 350 mm W117P	16x Ø6x13 mm e3



1

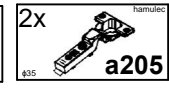
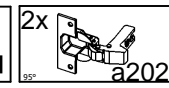
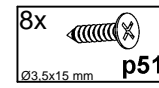
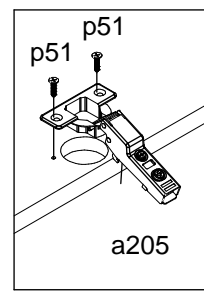
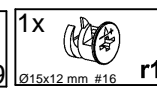
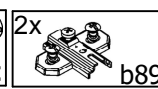
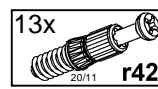
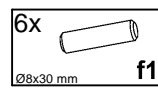
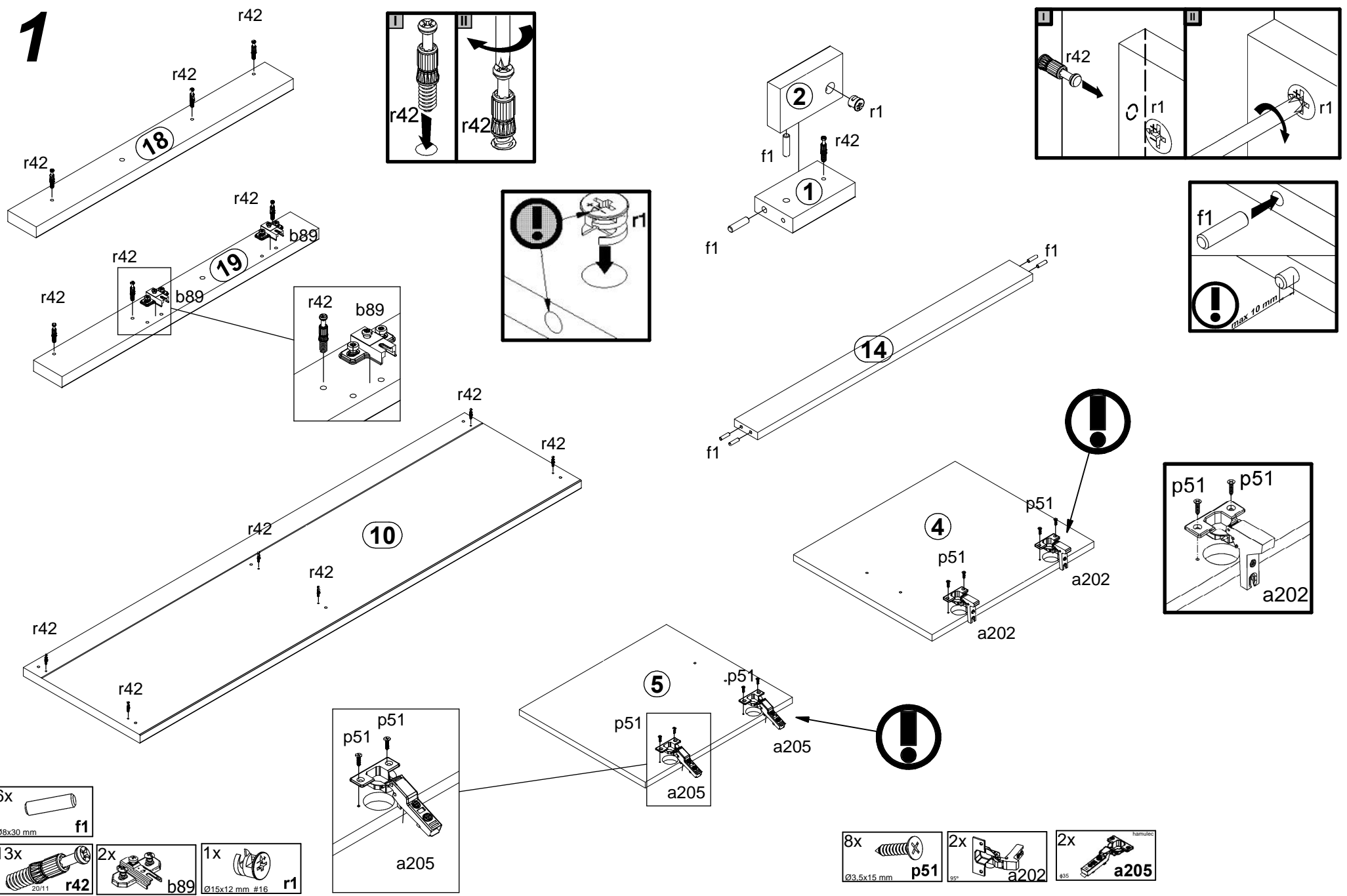

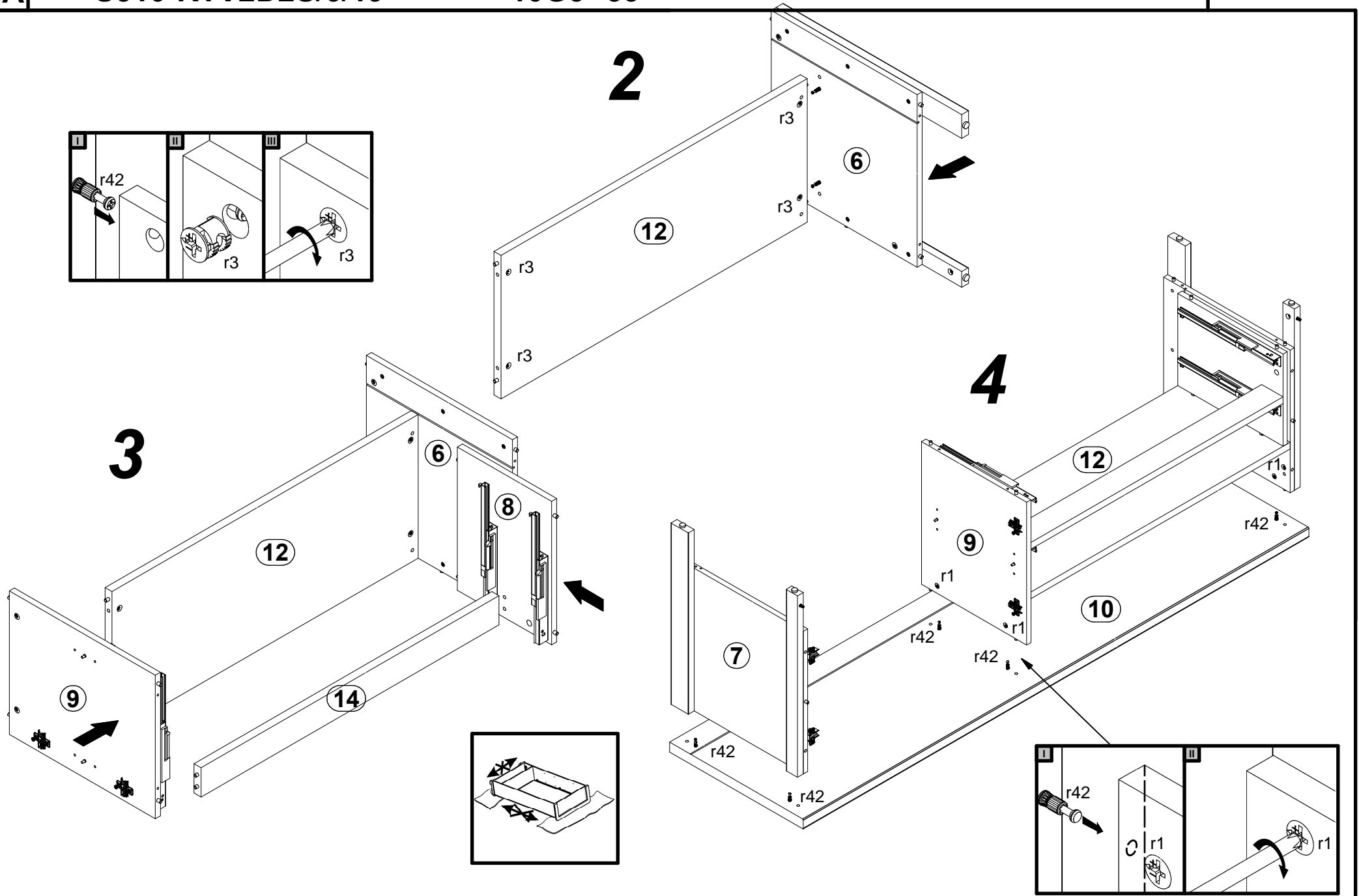

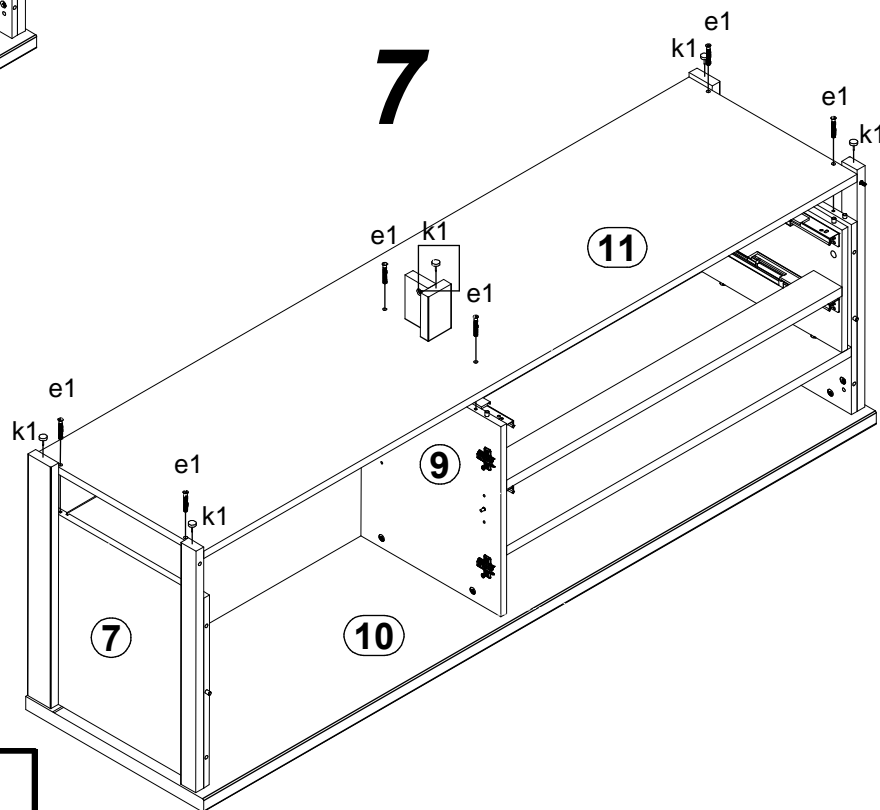
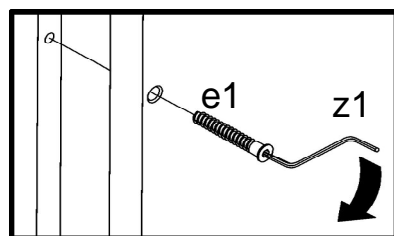
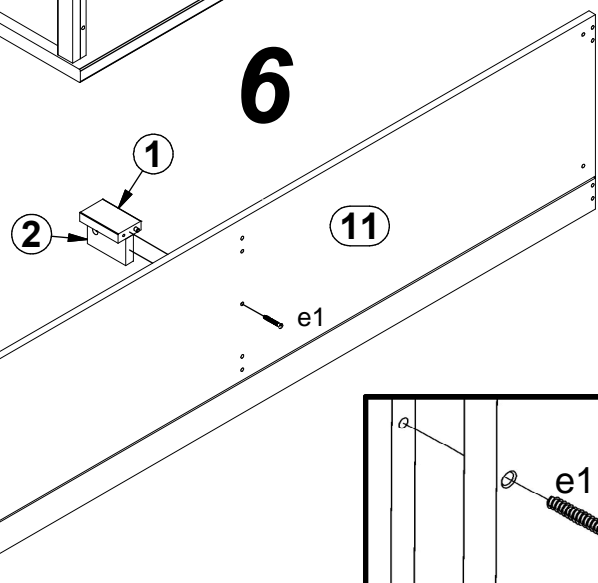
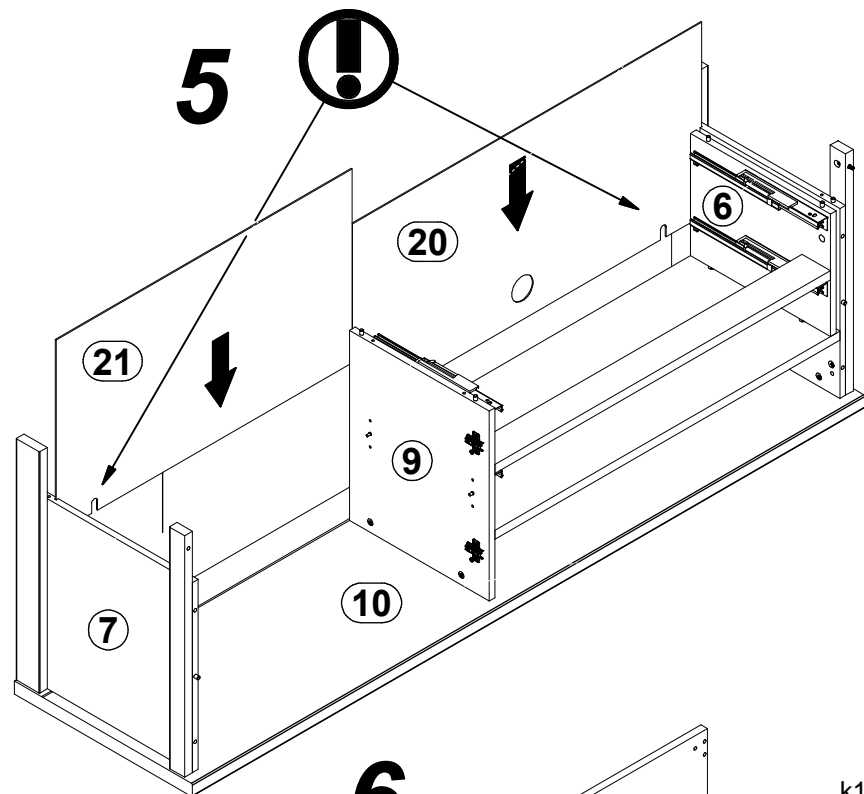
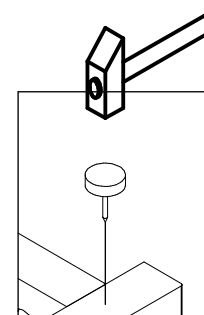
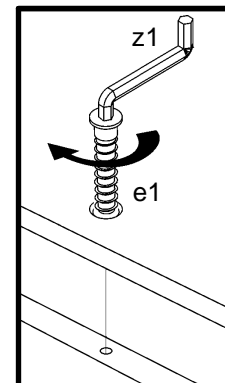
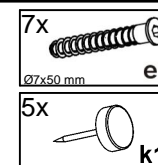
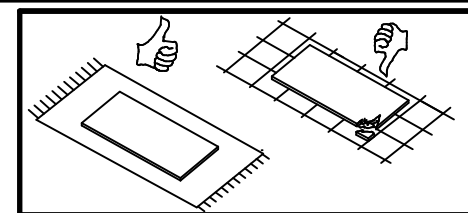

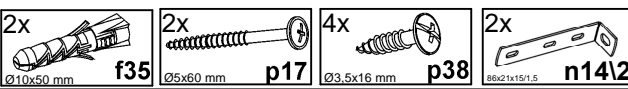
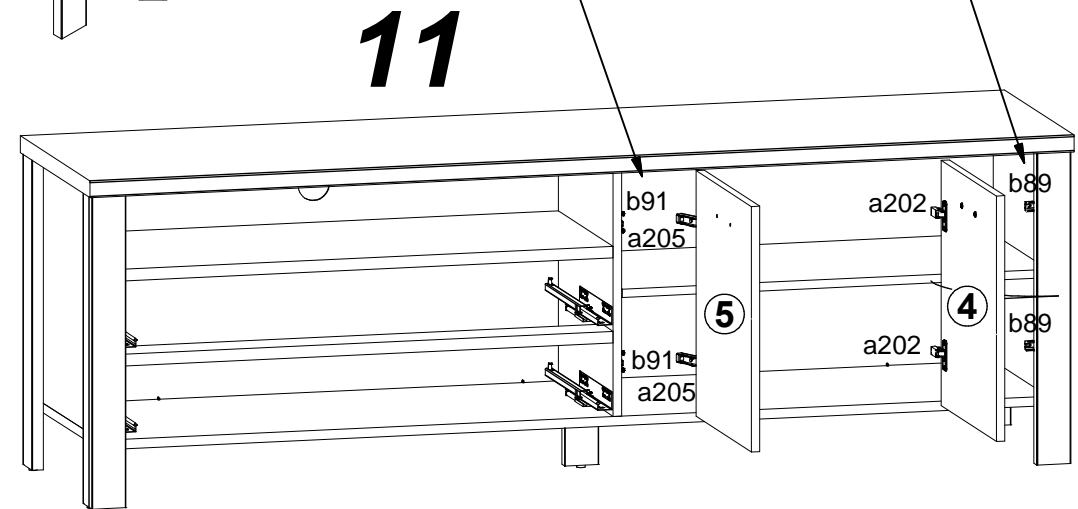
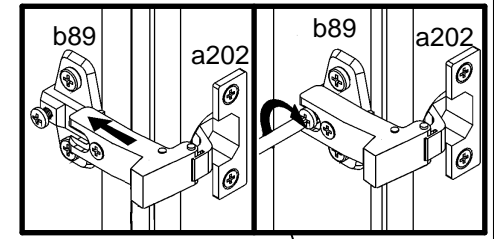
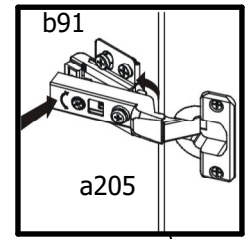
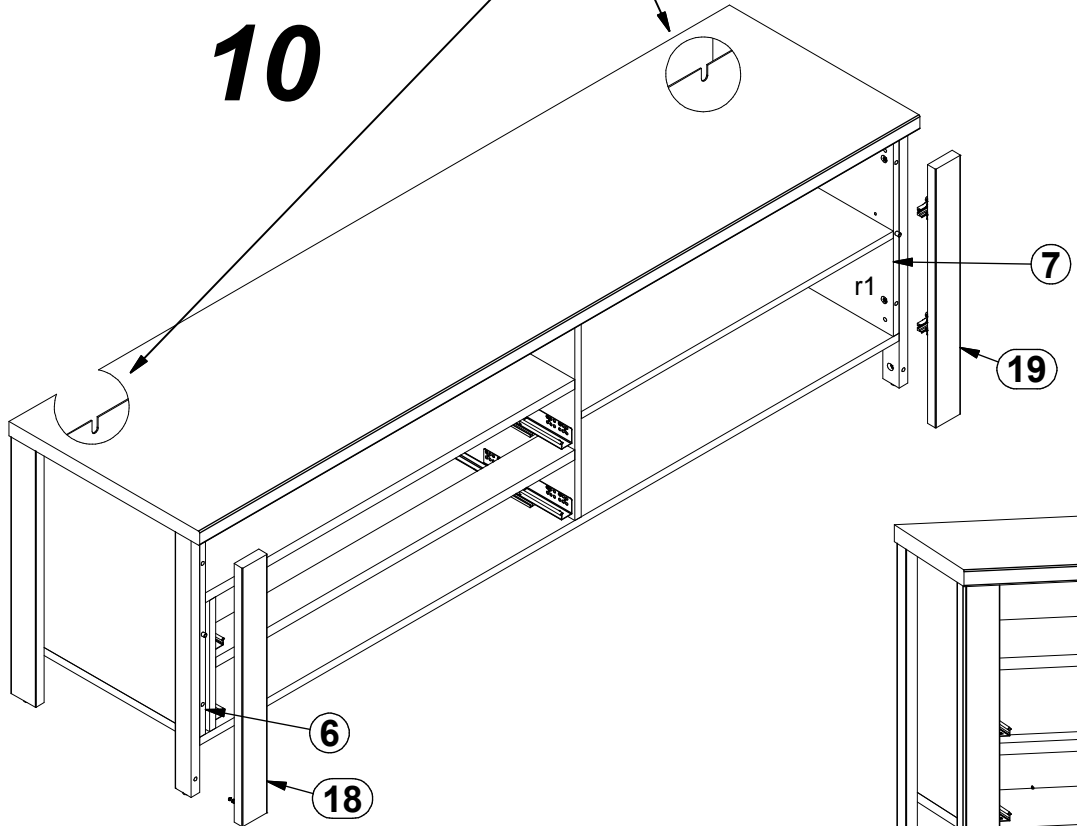
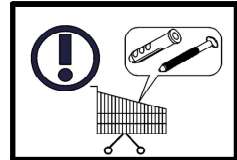
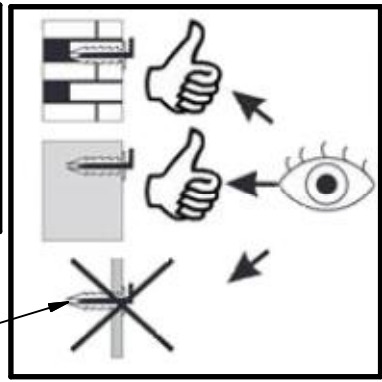
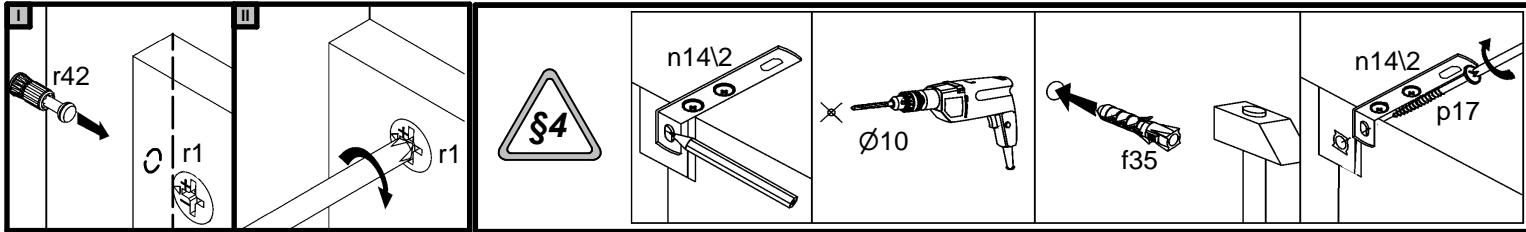



12

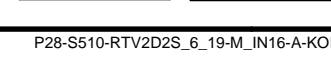
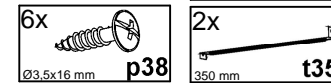
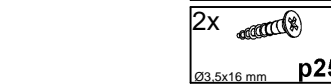
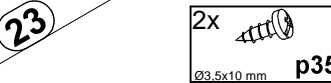
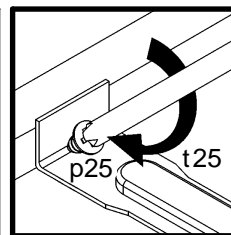
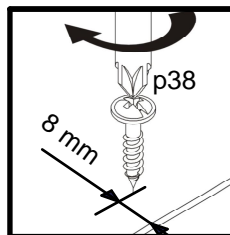
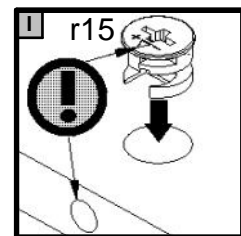
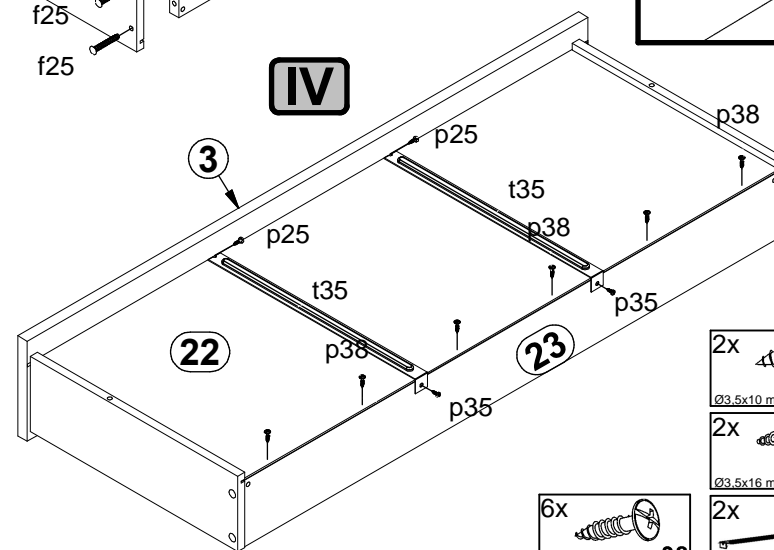
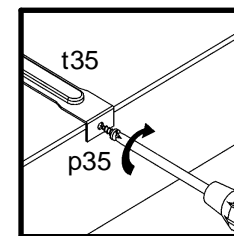
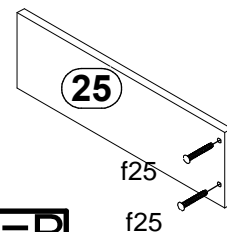
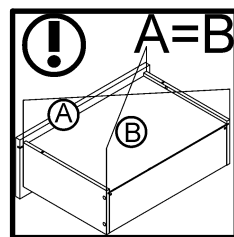
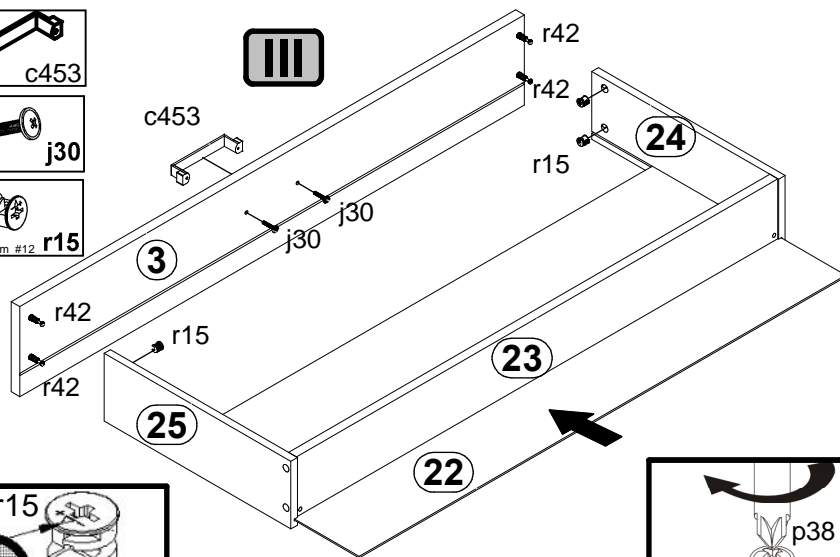
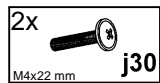
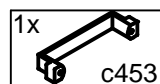
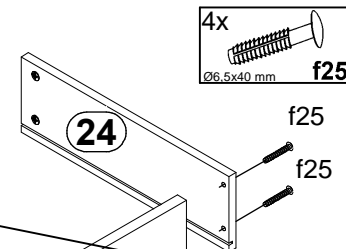
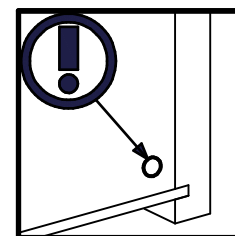
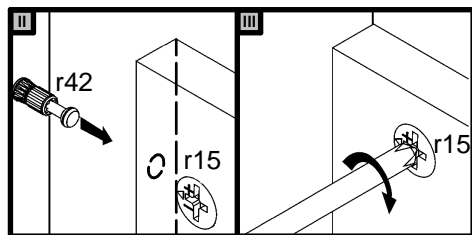
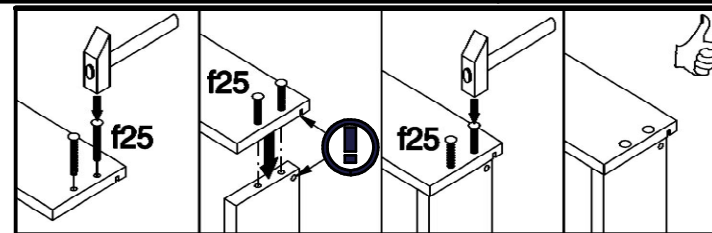
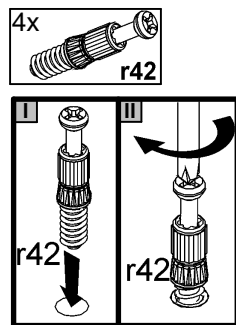
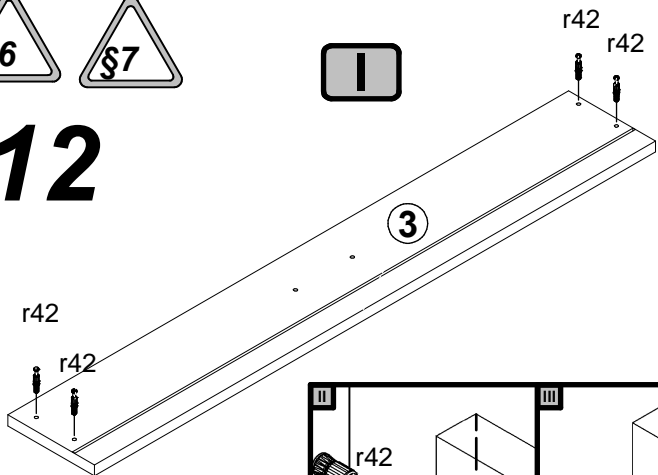

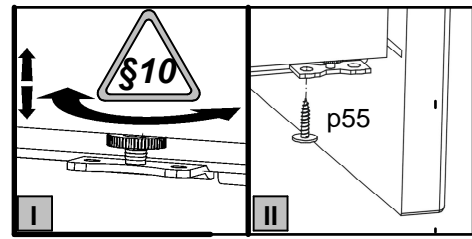
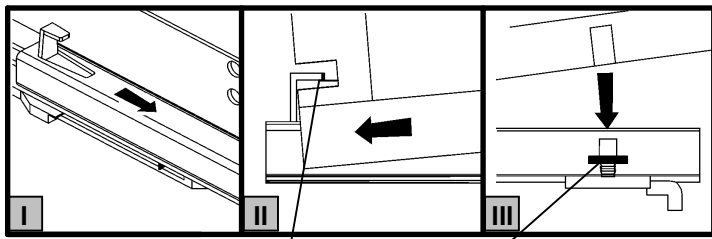

13

